



Policy Statement—Prevention of Choking Among Children

COMMITTEE ON INJURY, VIOLENCE, AND POISON PREVENTION

KEY WORDS

choking, food, toys

ABBREVIATIONS

NEISS-AIP—National Electronic Injury Surveillance System—All Injury Program

CPSC—Consumer Product Safety Commission

FHSA—Federal Hazardous Substance Act

CSPA—Child Safety Protection Act

SPTF—small-parts test fixture

AAP—American Academy of Pediatrics

FDA—Food and Drug Administration

USDA—US Department of Agriculture

This document is copyrighted and is property of the American Academy of Pediatrics and its Board of Directors. All authors have filed conflict-of-interest statements with the American Academy of Pediatrics. Any conflicts have been resolved through a process approved by the Board of Directors. The American Academy of Pediatrics has neither solicited nor accepted any commercial involvement in the development of the content of this publication.

www.pediatrics.org/cgi/doi/10.1542/peds.2009-2862

doi:10.1542/peds.2009-2862

All policy statements from the American Academy of Pediatrics automatically expire 5 years after publication unless reaffirmed, revised, or retired at or before that time.

PEDIATRICS (ISSN Numbers: Print, 0031-4005; Online, 1098-4275).

Copyright © 2010 by the American Academy of Pediatrics

abstract

Choking is a leading cause of morbidity and mortality among children, especially those aged 3 years or younger. Food, coins, and toys are the primary causes of choking-related injury and death. Certain characteristics, including shape, size, and consistency, of certain toys and foods increase their potential to cause choking among children. Childhood choking hazards should be addressed through comprehensive and coordinated prevention activities. The US Consumer Product Safety Commission (CPSC) should increase efforts to ensure that toys that are sold in retail store bins, vending machines, or on the Internet have appropriate choking-hazard warnings; work with manufacturers to improve the effectiveness of recalls of products that pose a choking risk to children; and increase efforts to prevent the resale of these recalled products via online auction sites. Current gaps in choking-prevention standards for children's toys should be reevaluated and addressed, as appropriate, via revisions to the standards established under the Child Safety Protection Act, the Consumer Product Safety Improvement Act, or regulation by the CPSC. Prevention of food-related choking among children in the United States has been inadequately addressed at the federal level. The US Food and Drug Administration should establish a systematic, institutionalized process for examining and addressing the hazards of food-related choking. This process should include the establishment of the necessary surveillance, hazard evaluation, enforcement, and public education activities to prevent food-related choking among children. While maintaining its highly cooperative arrangements with the CPSC and the US Department of Agriculture, the Food and Drug Administration should have the authority to address choking-related risks of all food products, including meat products that fall under the jurisdiction of the US Department of Agriculture. The existing National Electronic Injury Surveillance System—All Injury Program of the CPSC should be modified to conduct more-detailed surveillance of choking on food among children. Food manufacturers should design new foods and redesign existing foods to avoid shapes, sizes, textures, and other characteristics that increase choking risk to children, to the extent possible. Pediatricians, dentists, and other infant and child health care providers should provide choking-prevention counseling to parents as an integral part of anticipatory guidance activities. *Pediatrics* 2010;125:601–607

INTRODUCTION

Choking is the blockage or hindrance of respiration by a foreign-body obstruction in the internal airway, including the pharynx, hypopharynx, and trachea. Airway obstruction can be fatal if it leads to serious impair-

ment of oxygenation and ventilation. Choking is a leading cause of morbidity and mortality among children, especially those who are 3 years of age or younger. This is largely because of the developmental vulnerabilities of a young child's airway and the underdeveloped ability to chew and swallow food. Young children also commonly put objects in their mouths as they explore their environments.¹ The most common objects on which children choke are food, coins, balloons, and other toys.

FACTORS ASSOCIATED WITH THE ANATOMY AND FUNCTION OF THE AIRWAY

An infant is developmentally able to suck and swallow and is equipped with involuntary reflexes (gag, cough, and glottic closure) that help to protect against aspiration during swallowing. Dentition initially develops at approximately 6 months with eruption of the incisors. Molars are required for chewing and grinding food and do not erupt until approximately 1.5 years of age. However, mature mastication abilities take longer to develop and remain relatively incomplete throughout early childhood.^{2,3} Young children and children with developmental and neurologic impairment also do not have the overall cognitive skills, behavioral control, or experience to chew well and eat slowly.

Despite a strong gag reflex, a young child's airway is more vulnerable to obstruction than that of an adult in several ways. The smaller diameter is more likely to experience significant blockage by small foreign bodies. Resistance to air flow is inversely related to the radius of the airway to the fourth power, so even small changes in the cross-section of the airway of a young child can lead to dramatic changes in airway resistance and air flow. Mucus and secretions around a foreign body in the airway will reduce the radius of the airway even further and may also

form a seal around the foreign body, making it more difficult to dislodge by forced air, such as with a cough or Heimlich maneuver. The force of air generated by a cough in an infant or young child is less than that in an adult; therefore, a cough may be less effective in dislodging a complete or partial airway obstruction during early childhood.⁴

EPIDEMIOLOGY

Nonfatal Choking Episodes

A complete description of nonfatal choking events among children is limited, because many of these events are transient, do not result in aspiration, and consequently do not result in visits to health professionals. Many episodes, therefore, are not reported. Choking events that result in emergency medical treatment or bronchoscopy are the most serious of episodes and have been well described.^{5–8} Data are lacking regarding the long-term consequences of brain hypoxia caused by nonfatal choking; however, the morbidity in these cases can be severe.

The Centers for Disease Control and Prevention conducted an analysis of nonfatal choking episodes among children aged 14 years or younger treated in US hospital emergency departments during 2001 on the basis of data reported through the National Electronic Injury Surveillance System—All Injury Program (NEISS-AIP).⁹ Of an estimated 17 537 children aged 14 years or younger who were treated for nonfatal choking, more than half (59.5%) were treated for food-related choking, approximately one third (31.4%) were treated for choking on nonfood items, and the cause of choking for the remaining 9.1% was unknown. Almost 13% of all these choking episodes were associated with coins, and 19% were caused by candy or gum. These findings are similar to those reported in a comparative retrospective analysis of foreign-body-related injuries to chil-

dren from 1920–1932 and 1988–2000, confirming that food and coins are the most common foreign bodies.¹⁰ Coin-related choking episodes among children are usually transient, with the coin typically being swallowed. The coin usually passes through the gastrointestinal tract without problems but may lodge in the esophagus.

A Centers for Disease Control and Prevention report⁹ indicated that choking rates were highest among infants (140.4 per 100 000 population) and decreased consistently with increasing age, with an overall rate of 29.9 per 100 000 population among children aged 14 years and younger. Almost one third (30.5%) of choking episodes occurred among infants, and more than three fourths (77.1%) occurred among children aged 3 years or younger. Male and female children were treated for choking at similar rates: 32.1 and 27.3 per 100 000 population, respectively. An estimated 10.5% of children receiving emergency medical treatment were admitted to the hospital or transferred to a facility with advanced care available.⁹

Fatal Choking Episodes

From 1972 to 1992, 449 deaths from aspirated nonfood foreign bodies among children aged 14 years or younger were recorded by the US Consumer Product Safety Commission (CPSC). Nearly two thirds (65%) of these fatalities were among children younger than 3 years. Latex balloons were associated with 29% of deaths overall.¹¹ Choking on food causes the death of approximately 1 child every 5 days in the United States. Hot dogs accounted for 17% of food-related asphyxiations among children younger than 10 years of age in a 41-state study by Harris et al.¹²

NONFOOD-RELATED CHOKING

Coins and toys account for most nonfood-related choking events among children. Purchasing toys for children

with younger siblings poses a challenge to parents. They may find it difficult to meet the developmental play needs of the older child while addressing the safety needs of a younger sibling. Toys that are acceptable for older children sometimes have small or removable parts that can pose a choking risk to the younger brother or sister.

High-Risk Shapes, Sizes, and Consistencies

Of all children's products, latex balloons are the leading cause of choking death, and most of these fatalities are among children younger than 6 years.^{13,14} At least 68 children died from choking on latex balloons from 1990 through 2004 in the United States.¹⁵ Uninflated and pieces of broken latex balloons pose a particular hazard because of their ability to conform to the child's airway and form an airtight seal.

In addition to conforming objects, round, ovoid, or cylindrical objects such as balls, marbles, and spherical toys or toy parts pose the greatest risk of choking death.^{11,15} When these objects are approximately the same diameter as a child's upper airway, they can completely occlude the airway with a snug fit and are difficult to dislodge with rescue maneuvers.

Monitoring and Enforcement by the CPSC

The Federal Hazardous Substance Act (FHSA) (Pub L No. 86–613 [1960]) was amended in 1994 by the Child Safety Protection Act (CSPA) (Pub L No. 109–248). The CSPA requires choking-hazard warning labels on packaging for small balls, balloons, marbles, and certain toys and games that contain small parts when these items are intended for use by children in defined age groups. This act also bans any toy intended for use by children younger than 3 years that may pose a chok-

ing, aspiration, or ingestion hazard. The CPSC created a CSPA fact sheet¹⁶ (www.cpsc.gov/cpsc/pub/pubs/282.html) that lists the required warning statement for each item when intended for use by defined age groups. Section 1501 of the FHSA defines a test of object size using the small-parts test fixture (SPTF). The SPTF is a truncated cylinder with a diameter of 3.17 cm (1.25 in), simulating the mouth, and a depth between 2.54 and 5.71 cm (1.00 and 2.25 in), simulating the pharynx (Fig 1). An object is considered a small part if it fits completely within the SPTF. The SPTF was developed, in part, on the basis of data regarding the dimensions of airway foreign bodies recovered by bronchoscopy by Chevalier Jackson in the early 1900s.⁸ Because of their high-risk shape, small balls are held to a stricter criterion to prevent choking. The CSPA requires that balls be at least 1.75 inches in diameter if they are intended for use by children younger than 3 years. The CSPA defines a ball as a spheroid, ovoid, or elliptical

object that is designed or intended to be thrown, hit, kicked, rolled, bounced, or dropped.

In addition, the Consumer Product Safety Improvement Act of 2008 (Pub L No. 110–314) amended the FHSA to require choking-hazard warnings to be displayed on or adjacent to product advertisements on Web sites or in catalogs or other printed materials that provide a direct means for purchase or order of a product for which a warning is required under the FHSA.

High-Risk Settings and Circumstances

In a study that predated the CSPA, Rimmell et al¹¹ examined 101 foreign bodies that had caused a choking death and found that 14 passed requirements for use by children younger than 3 years. In another study on airway foreign bodies, Reilly et al concluded that greater child protection would be achieved if the diameter of the SPTF was increased from 1.25 to 1.75 in.¹⁰ Milkovich et al¹⁷ examined approximately 7000 foreign-body injuries from 15 countries and recommended the use of a 1.50-in-diameter test device for nonspherical objects and a 1.75-in-diameter test device for spherical objects. The ball test fixture defined in the CSPA has a 1.75-in diameter; however, there are spheroid, ovoid, or elliptical toys or toy parts that do not meet the definition of a ball but present the same cross-sectional profile to a child's airway. Although these spheroid, ovoid, or elliptical nonball objects present an increased risk of fatal choking to young children, similar to the increased risk of fatal choking associated with balls, they currently are not held to the stricter choking-prevention standard applied to balls. Therefore, these gaps in choking-prevention standards for children's toys should be reevaluated and addressed, as appropriate, via revi-

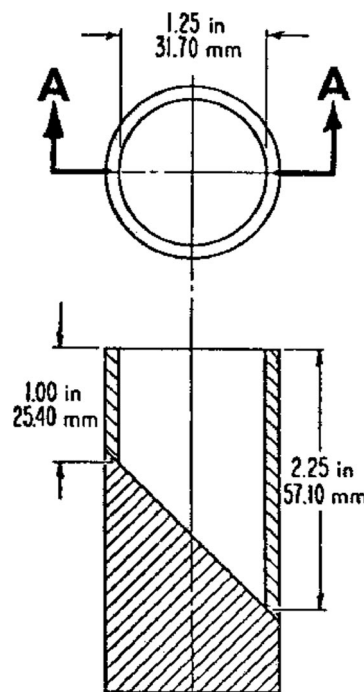

FIGURE 1
The SPTF.

sions to the CPSA or regulation by the CPSC.

Because the CPSC does not conduct premarket testing of toys, consumers need to be aware that just because a toy is on the market does not guarantee its safety. Consumers should be proactive in evaluating toy features that may pose a danger to a child before the toy is purchased and given to a child. Toys sold in retail store bins, vending machines, and on the Internet may not be consistently marked with appropriate warning labels and, thus, present a challenge to consumers who wish to make informed safe purchases. Toys resold in yard sales, at secondhand stores, and via online auction Web sites commonly lack appropriate cautionary labeling and information.¹⁸ Choking risk to children younger than 3 years is the most common reason for the CPSC to issue a recall notice for a children's product; however, the effectiveness of children's product recalls is very low. For example, consumers generally return only 10% to 30% of sold infant products after they have been recalled.¹⁹ Recalled children's products are commonly resold on online auction Web sites.¹⁸

FOOD-RELATED CHOKING

Choking on food poses an important and relatively underaddressed problem for US children. Approximately 66 to 77 children younger than 10 years of age die from choking on food each year in the United States,¹² and >10 000 emergency department visits annually can be attributed to choking on food among children aged 14 years and younger.⁹

High-Risk Foods and Food Characteristics

Hot dogs are the food most commonly associated with fatal choking among children.¹² A hot dog shares the physi-

cal characteristics described above for high-risk toys. It is cylindrical, airway sized, and compressible, which allows it to wedge tightly into a child's hypopharynx and completely occlude the airway. Other high-risk foods include hard candy, peanuts/nuts, seeds, whole grapes, raw carrots, apples, popcorn, chunks of peanut butter, marshmallows, chewing gum, and sausages.¹² Many of these foods, such as round candy, grapes, marshmallows, and meat sticks/sausages, share the same high-risk physical characteristics that create effective plugs for the pediatric airway. Similar to latex balloons, peanut butter can conform to the airway and form a tenacious seal that is difficult to dislodge or extract. It is noteworthy that many foods with high-risk characteristics associated with choking are man-made. The characteristics of these foods are engineered and, therefore, amenable to change, unlike naturally occurring food products such as certain fruits and vegetables. Manufacturers of foods that are frequently consumed by children should, to the extent possible, design these products to minimize choking risk to those in that age group.

Child Risk Factors

The American Academy of Pediatrics (AAP) Section on Breastfeeding and many other health organizations recommend exclusive breastfeeding for the first 6 months of life.²⁰ The AAP Committee on Nutrition recommends that complementary foods be introduced between 4 and 6 months of age.²¹ Children younger than 4 years and children with chewing and swallowing disorders are at greater risk of food-related choking. Before the molars erupt, children are able to bite off a piece of food with their incisors but are unable to grind it adequately in preparation for swallowing. Children 3 to 4 years old have molars but are still learning to chew effectively.^{2,3} Children

at this age also may be easily distracted when they need to pay full attention to the task of eating. Children with swallowing disorders are at increased risk of choking. Neuromuscular disorders, developmental delay, traumatic brain injury, and other primary and secondary medical conditions may adversely affect the complex neuromuscular coordination involved in the swallowing process.²² Therefore, caregivers should pay special attention to choking prevention among children with such neurologic impairments regardless of the age of the child.

Behavioral factors may also affect a child's risk for choking. High activity levels while eating, such as walking or running, talking, laughing, and eating quickly, may increase a child's risk of choking.¹² Child games that involve throwing food in the air and catching it in the mouth or stuffing large numbers of marshmallows or other food in the mouth also may increase the risk of choking.

Prevention of Food-Related Choking

Increased federal action to prevent choking on food by young children should include surveillance, cautionary food labeling, recalls when necessary, and public education. These actions will encourage food manufacturers to give greater attention to child safety and modify their products to prevent choking-related injury. Current systems for conducting injury surveillance (such as the NEISS-AIP) and strategies for prevention of choking associated with toys have direct application to the problem of food-related choking in the same high-risk group of young children.

Need for Increased Federal Regulation of Choking Hazards

Although the CPSC has well-established surveillance systems and an array of

legislation and regulations to protect children against choking and injury on toys and other consumer products, there are currently no counterpart surveillance systems, laws, regulations, or dedicated resources to protect children against choking on food, yet food is more likely to go into a child's mouth than a toy. A mandatory system is needed to label foods with appropriate warnings according to their choking risk, to conduct detailed surveillance and investigate food-related choking incidents, and to warn the public about emerging food-related choking hazards. As has been proposed through federal legislation, the US Food and Drug Administration (FDA) should be responsible for these measures and should work closely with the CPSC to integrate food-related hazards into product recalls and public notices. This collaborative effort would build on the support currently being provided by the CPSC to the FDA to identify food-related choking hazards. The NEISS-AIP currently collects information on food-related choking requiring an emergency department visit; however, more detail about the types of food and the choking events needs to be incorporated into the surveillance system. Enabling federal legislation with appropriate additional funding for implementing these changes should be enacted as needed.

Although some food manufacturers voluntarily label foods with choking warnings, all companies should provide appropriate warning labels, either voluntarily or through mandatory measures. Other countries are ahead of the United States in this regard. For example, Sweden has had age labeling on foods for infants and young children since 1979 and warning labels on prepackaged shelled peanuts since 1981 to prevent choking among young children.^{12,23,24} The FDA should collaborate with the US Department of Agricul-

ture (USDA), which has jurisdiction over the safety of meat products such as hot dogs. There is a precedent for such collaboration; the FDA and USDA worked together on a National Task Force on Foods and Choking in Children convened by the AAP in 1983.

An example of the involvement of the FDA in ensuring children's safety from food-related choking is its response to the hazard of gel candy. During a relatively short period, there were at least 6 choking deaths and a series of aspirations and near-deaths among children associated with gel candies containing the ingredient konjac.²⁵ The dimensions (which approximated the diameter of a child's upper airway), rounded shape, consistency, and slipperiness of the product contributed to a serious choking risk. Indeed, these characteristics are very similar to those of the rounded end of a hot dog, a known high-risk food for young children. These candies were packaged in rounded cups as individual mouth-size servings designed to be sucked out of the cups by the consumer. Unlike most gel products, these candies did not dissolve when in the mouth. The consumption method also contributed to the choking risk, because the candy was intended to be sucked out of its packaging.

In 2002, the FDA seized the candies at 1 manufacturer's facility in California and issued general warnings against consuming products containing konjac. The FDA also issued an import alert to prevent this product from entering the country and declared the candy as "unfit for food" under the Federal Food Drug and Cosmetic Act.²⁶ The action of the FDA likely prevented additional choking episodes; however, other children might have been saved had a coordinated surveillance system and mechanism for determining choking hazards associated with food already been in place. In addition, the similar characteristics of the gel candy and a

hot dog (and also small balls and other high-risk toys) should have alerted public health officials to the inherent choking risk for children posed by this gel candy product.

Legislation to Prevent Food-Related Choking

Legislation focused on reducing the risk of choking on food by children was introduced, but never enacted, in each session of Congress from 2002 through 2006. The Food Choking Prevention Act went through 3 iterations and proposed various measures on food-choking prevention and education.²⁷⁻²⁹ In different drafts of the bill, the proposals ranged from simple educational efforts and research to the establishment of an FDA Office of Choking Hazard Evaluation. State legislation addressing food-choking hazards to children has been enacted, including a law passed in 2007 in New York³⁰ that gave authority to the New York State Department of Health to establish age-differentiated criteria for defining foods that pose a significant and unacceptable choking hazard, produce and distribute educational materials, conduct a public education program, and establish a statewide database of food-choking incidents.

CONCLUSIONS

Choking is an important public health problem for young children. Choking hazards are primarily associated with food, coins, and toys. A comprehensive choking-prevention effort will rely on education of parents, teachers, child care workers, and other child caregivers to supervise and create safer environments for children; enactment and enforcement of safety legislation that will lead to surveillance and reduction of the availability of hazardous products on the market; and product-design changes that will reduce the inherent choking risk of consumer products, especially food and toys.

RECOMMENDATIONS

1. The FDA should establish a systematic, institutionalized process for examining and addressing the hazards of food-related choking, which should include the establishment of the necessary surveillance, hazard-evaluation, enforcement, and public-education activities to prevent food-related choking among children. Specifically, the authority and activities of the FDA should be enhanced to permit the agency to:
 - Evaluate foods and require warning labels on foods that pose a high choking risk to children. The FDA should collaborate with the USDA to ensure that meat products also undergo similar evaluation and labeling.
 - Recall food products that pose a significant and unacceptable choking hazard to the public. The FDA should collaborate with the USDA to ensure that a similar recall process exists for meat products.
 - Establish a national food-related choking-incident surveillance and reporting system to warn the public of existing and emerging hazards. The NEISS-AIP of the CPSC should be modified to provide the surveillance function of this system.
 - Conduct, in consultation with the USDA, CPSC, AAP, and other organizations, a widely publicized food-related choking-prevention campaign that is focused on children.
 - Focus resources and prevention

program efforts on high-risk groups, circumstances, and products that are identified through the surveillance system.

- Maintain highly cooperative arrangements with the CPSC and USDA, and information should be openly shared among these agencies.
2. Pediatricians, dentists, and other infant and child health care professionals should intensify choking-prevention counseling as an integral part of anticipatory guidance activities.
 3. Pediatricians should continue to provide parents and caregivers guidance on appropriate food and toy selection with respect to choking prevention as outlined by the AAP.^{51–55}
 4. Food manufacturers should design new foods and redesign existing foods, including meat products, to avoid shapes, sizes, textures, and other characteristics that increase choking risk to children, to the extent possible.¹²
 5. The CPSC should increase efforts to ensure that toys that are sold in retail store bins, in vending machines, or online have appropriate choking-hazard warnings; work with manufacturers to improve the effectiveness of recalls of products that pose a choking risk to children; and increase efforts to prevent the resale of these recalled products on online auction sites. Current gaps in choking-prevention standards for children's toys should be reevaluated

and addressed via revisions to the standards established under the CSPA or the Consumer Product Safety Improvement Act or via regulation by the CPSC.

6. Because it is impossible to prevent all choking episodes among children, cardiopulmonary resuscitation and choking first aid for children should be taught to parents, teachers, child care providers, and others who care for children, particularly children at high risk of choking.

COMMITTEE ON INJURY, VIOLENCE, AND POISON PREVENTION, 2007–2008

H. Garry Gardner, MD, Chairperson
Carl R. Baum, MD
M. Denise Dowd, MD, MPH
Dennis R. Durbin, MD, MSCE
Richard Lichenstein, MD
Kyran P. Quinlan, MD, MPH
Robert D. Sege, MD, PhD
Michael S. Turner, MD
Jeffrey C. Weiss, MD

PAST COMMITTEE MEMBER

*Gary A. Smith, MD, DrPH, Immediate Past Chairperson

LIAISONS

Julie Gilchrist, MD – *Centers for Disease Control and Prevention*
Lynne J. Haverkos, MD – *Eunice Kennedy Shriver National Institute of Child Health and Human Development*
Jonathan D. Midgett, PhD – *Consumer Product Safety Commission*
Lori Roche – *Health Resources and Services Administration*
Alexander S. Sinclair – *National Highway Traffic Safety Administration*
Lynne J. Warda, MD – *Canadian Paediatric Society*

STAFF

Bonnie Kozial
bkozial@aap.org

*Lead author

REFERENCES

1. Smith SA, Norris B. Reducing the risk of choking hazards: mouthing behavior of children aged 1 month to 5 years. *Inj Control Saf Promot.* 2003;10(3):145–154
2. Reilly JS, Cook SP, Stool D, Rider G. Prevention and management of aerodigestive foreign body injuries in childhood. *Pediatr Clin North Am.* 1996;43(6):1403–1411
3. Carruth BR, Skinner JD. Feeding behaviors and other motor development in healthy children (2–24 months). *J Am Coll Nutr.* 2002; 21(2):88–96
4. Foltin GL, Tunik M, Cooper A, et al, eds. *Teaching Resources for Instructors in Prehospital Pediatrics (TRIPP): Respiratory Emergencies.* Vol 2.0. New York, NY: Center for Pediatric Emergency Medicine; 1988
5. Blazer S, Naveh Y, Friedman A. Foreign body in the airway: a review of 200 cases. *Am J Dis Child.* 1980;134(1):68–71
6. Tan HKK, Brown K, McGill T, Kenna MA, Lund DP, Healy GB. Airway foreign bodies (FB): a 10-year review. *Int J Pediatr Otorhinolaryngol.* 2000;56(2):91–99
7. Jackson C. Foreign bodies of the larynx, trachea, bronchi and esophagus etiologically

- considered. *Trans Soc Laryngol Otol Rhinol Am Med Assoc.* 1917;36–56
8. Jackson C, Jackson CL. *Diseases of the Air and Food Passages of Foreign Body Origin.* Philadelphia, PA: Saunders; 1936
 9. Centers for Disease Control and Prevention. Nonfatal choking-related episodes among children: United States, 2001. *MMWR Morb Mortal Wkly Rep.* 2002;51(42):945–948
 10. Reilly BK, Stool D, Chen X, Rider G, Stool SE, Reilly JS. Foreign body injury in children in the twentieth century: a modern comparison to the Jackson collection. *Int J Pediatr Otorhinolaryngol.* 2003;67(suppl 1): S171–S174
 11. Rimell FL, Thome A Jr, Stool S, et al. Characteristics of objects that cause choking in children. *JAMA.* 1995;274(22):1763–1766
 12. Harris CS, Baker SP, Smith GA, Harris RM. Childhood asphyxiation by food: a national analysis and overview. *JAMA.* 1984;251(17): 2231–2235
 13. Centers for Disease Control and Prevention. Toy-related injuries among children and teenagers: United States, 1996. *MMWR Morb Mortal Wkly Rep.* 1997;46(50): 1185–1188
 14. Abdel-Rahman HA. Fatal suffocation by rubber balloons in children: mechanism and prevention. *Forensic Sci Int.* 2000;108(2): 97–105
 15. US Public Interest Research Group. *Trouble in Toyland: The 20th Annual Survey of Toy Safety.* Washington, DC: US Public Interest Research Group Educational Fund; 2005. Available at: <http://toysafety.net/2005/troubleintoyland2005.pdf>. Accessed December 1, 2008
 16. US Consumer Product Safety Commission. Child safety protection act fact sheet: CPSC document #282. Available at: www.cpsc.gov/cpsc/pub/pubs/282.html. Accessed December 1, 2008
 17. Milkovich SM, Rider G, Greaves D, Stool D, Chen X. Application of data for prevention of foreign body injury in children. *Int J Pediatr Otorhinolaryngol.* 2003;67(suppl 1): S179–S182
 18. Brown Kirschman K, Smith GA. Resale of recalled children's products online: an examination of the world's largest yard sale. *Inj Prev.* 2007;13(4):228–231
 19. Felcher ME. *It's No Accident: How Corporations Sell Dangerous Baby Products.* Philadelphia, PA: Common Courage Press; 2001
 20. American Academy of Pediatrics, Section on Breastfeeding. Breastfeeding and the use of human milk. *Pediatrics.* 2005;115(2): 496–506. Available at: www.pediatrics.org/cgi/content/full/115/2/496
 21. American Academy of Pediatrics. Complementary feeding. In: Kleinman RE, ed. *Pediatric Nutrition Handbook.* 6th ed. Elk Grove Village, IL: American Academy of Pediatrics; 2009:113–142
 22. Palmer JB, Drennan JB, Baba M. Evaluation and treatment of swallowing impairments. *Am Fam Physician.* 2000;61(8):2453–2462
 23. Swedish National Food Administration. The National Food Administration's Ordinance on Foods for Infants and Young Children (SLV FS1978;17, §15). Uppsala, Sweden: Food Standards Division; 1978
 24. Swedish National Food Administration. Agreement Regarding Certain Marking of Peanut Packages (SLV Announcement No. M 3/81). Uppsala, Sweden: Department of Standards; 1981
 25. Qureshi S, Mink R. Aspiration of fruit gel snacks. *Pediatrics.* 2003;111(3):687–689
 26. US Food and Drug Administration. New Choice agrees to withdraw remaining gel snacks on US market. *FDA News.* November 6, 2002:2–47
 27. Food Choking Prevention Act of 2002. HR 5739, 107th Congr (2002)
 28. Food Choking Prevention Act of 2003. HR 2773, 108th Congr (2003)
 29. Food Choking Prevention Act. HR 3560, 109th Congr (2005)
 30. JT's Law. Public Health, Article 2, Title 1, §201, subdivision 2-a, Consolidated Laws of New York. Available at: <http://caselaw.lp.findlaw.com/nycodes/PBH2500-ITXPBH02500-I.html>. Accessed December 11, 2008
 31. Glassy D, Romano J; American Academy of Pediatrics, Committee on Early Childhood, Adoption, and Dependent Care. Selecting appropriate toys for young children: the pediatrician's role. *Pediatrics.* 2003;111(4 pt 1):911–913
 32. American Academy of Pediatrics, Committee on Injury and Poison Prevention. *Injury Prevention and Control for Children and Youth.* Widome MD, ed. 3rd ed. Elk Grove Village, IL: American Academy of Pediatrics; 1997
 33. American Academy of Pediatrics, Committee on Injury, Violence, and Poison Prevention. *TIPP: The Injury Prevention Program.* Elk Grove Village, IL: American Academy of Pediatrics; 1994
 34. American Academy of Pediatrics. *Choking Prevention and First Aid for Infants and Children.* Elk Grove Village, IL: American Academy of Pediatrics; 2006
 35. American Academy of Pediatrics, Bright Futures Steering Committee. *Bright Futures: Guidelines for Health Supervision of Infants, Children, and Adolescents.* Haġan JF, Shaw JS, Duncan PM, eds. 3rd ed. Elk Grove Village, IL: American Academy of Pediatrics; 2008